

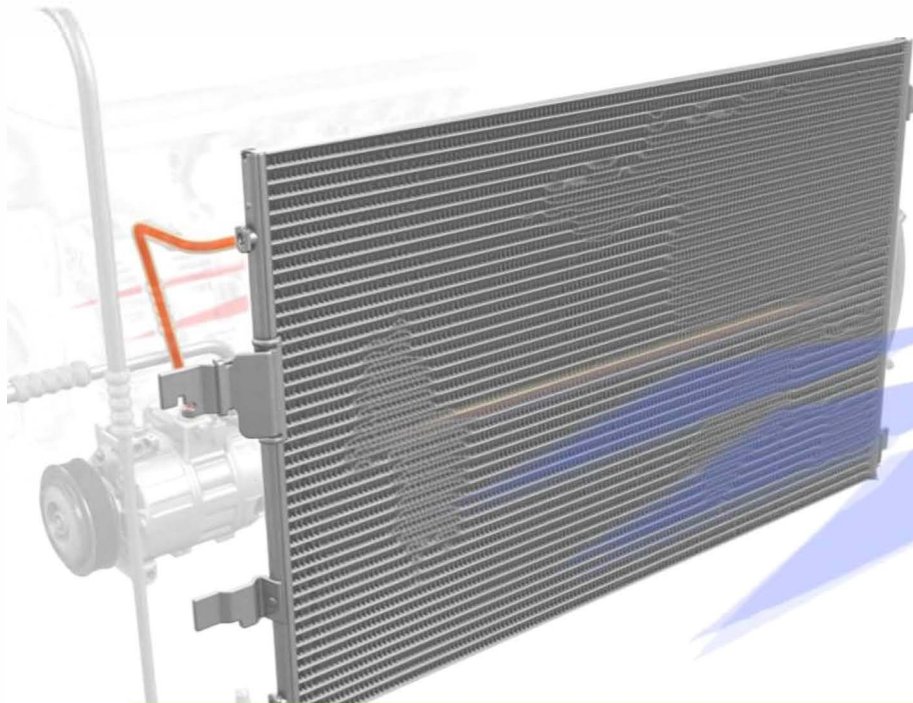

## Agrément Crédit d'impôt Recherche

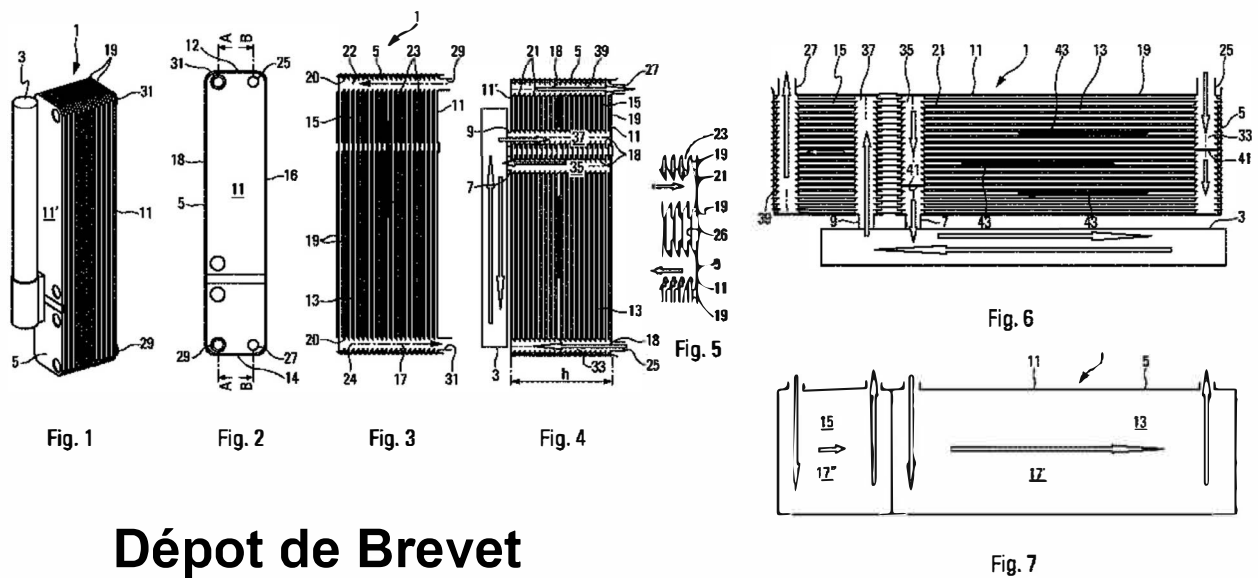

Condenseur de climatisation



## Dépot de Brevet